



# JIS10K SS316 GLOBE VALVES

## Literature



## Introduction:

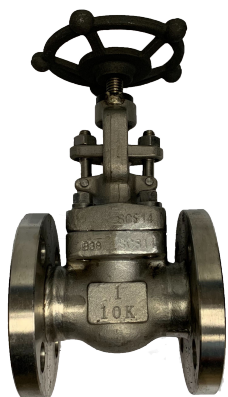

Figure 1 JIS 10K SS316 Globe Valve

Globe valves are installed on pipelines to allow, stop and regulate the flow of fluids. The hand wheel type handle will be rotated towards open position or close position to lifting up or lifting down the disc vertically along the seat. It is designed and manufactured according to ASME B16.10/ASME B16.34/API 602/F7307 standard. It also went through inspection and testing according to API 598/JIS F7400 standard. Globe valve is suitable to install on pipeline systems that require flow regulating action such as cooling water systems and fuel oil systems.

## Material and Design:

JIS10K flange end globe valve is available in stainless steel SS316 or cast iron material. The cover of JIS flange end globe valve is designed in bolted cover type, as the design might be different in shape due to different design standards. Bolted bonnet type is where the bonnet is attached to the valve body which holds the internal parts by tightening screws and nuts.

The stem of the globe valve is available in rising stem design and non-rising stem design. For globe valves that come with rising stem design, the stem will rise and be exposed when the wheel handle is turned to open position and lower when the wheel handle is turned to close position. By having a rising stem design globe valve installed on the pipeline system, it can tell us if the valve is in open position or close position by referring to the amount of stem exposed.

For globe valves with non-rising stem design, the valve is in open position when we turn the handle towards open position as far as possible and in close position when we turn the handle towards close position as far as possible. However it is unable to check the valve in open or close position like rising stem design. Non-rising stem design globe valve is suitable to install on pipelines that have limited space for rising stem design, for example, underground hydraulic systems.

## Size and Pressure Rating:

The available size for the globe valve is ranged from 1" to 6", subject to material. JIS 10K flange end globe valve can withstand up to 10kg/cm<sup>2</sup> which is equivalent to 150 PSI working pressure.

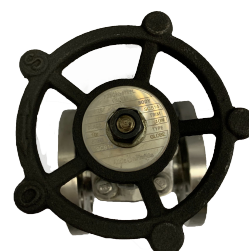
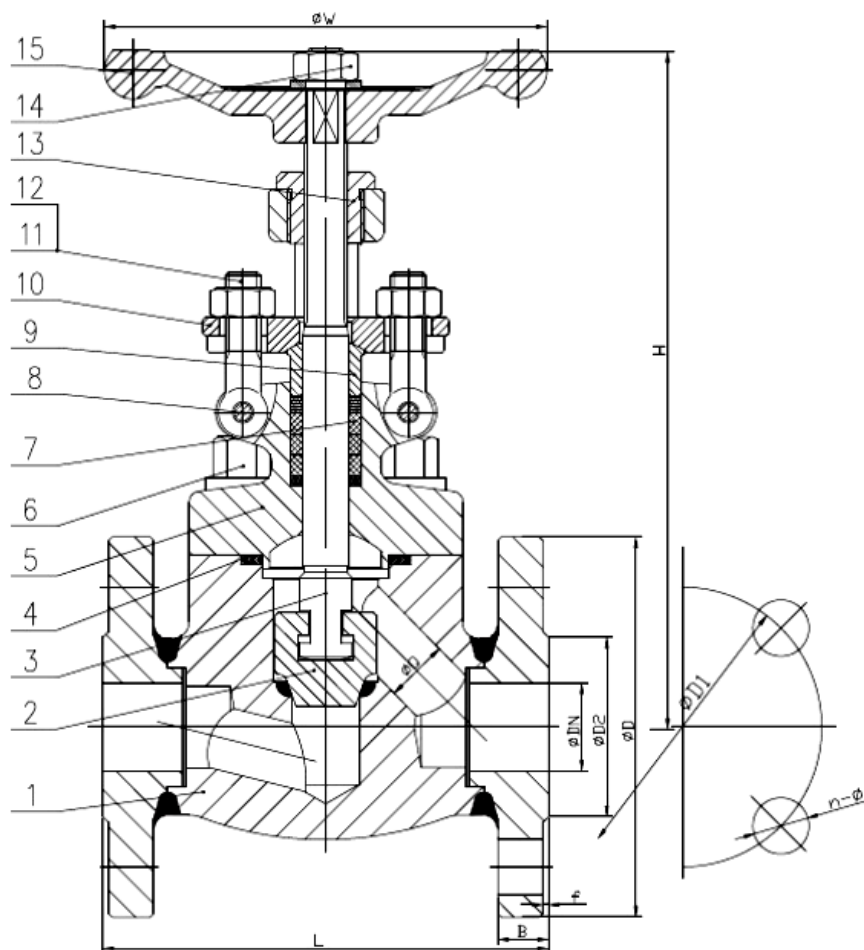

Figure 2 JIS 10K SS316 Globe Valve

## Connection Type:

For the flange end globe valve, the connection comes with both end flanges which the other end connection must be flange end too to connect. The number of bolt holes is dependent on valve size, 4 bolt holes for size below 4" and 8 bolt holes for size above 4". Other accessories such as gasket, bolts and nuts are required to connect the both flanges together.

**JIS 10K SS316 Globe Valve 1" – 1 1/2" (DN25 - DN40) Drawing:**

No	Part Name	Material
1	Body + Seat	ASTM A182 F316
2	Disc	ASTM A182 F316
3	Stem	ASTM A182 F316
4	Gasket	SS316 + Graphite
5	Bonnet	ASTM A182 F316
6	Bonnet Bolt	ASTM A193 B8M
7	Packing	Graphite
8	Pin	ASTM A182 F316
9	Gland	ASTM A182 F316

10	Gland Flange	ASTM A182 F316
11	Gland Bolt	ASTM A193 B8M
12	Gland Nut	ASTM A194 8M
13	Yoke Sleeve	ASTM A276 410
14	Lock Nut	Carbon Steel
15	Handwheel	ASTM A197

**Main Technical Parameter:**

<b>Normal Pressure</b>	10K
<b>Shell Test Pressure</b>	3.0 MPa
<b>Seal Test</b>	2.2 MPa
<b>Gas-Tightness Test</b>	0.6 MPa
<b>Max Working Pressure</b>	-29°C to 425°C

**Technical Specifications:**

1. Basic design and manufacture according to API602/BS5352
2. Face to face dimension: ASME B16.10
3. Flange End: JIS B2220;2012 RF
4. Inspection and test: API 598

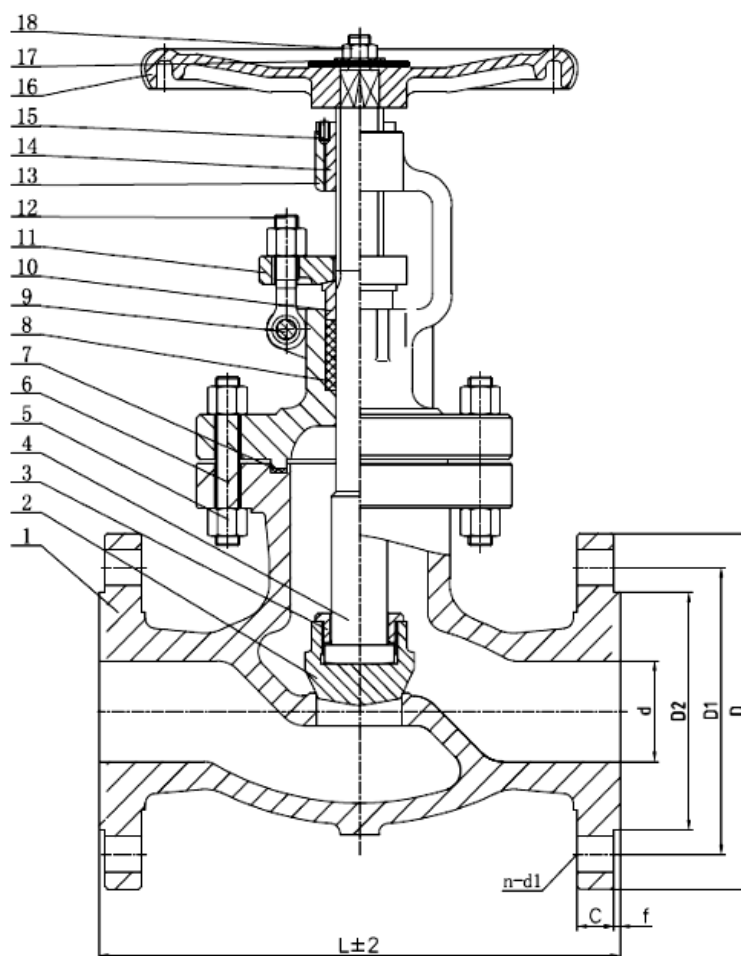
**JIS 10K SS316 Globe Valve 2" – 4" (DN50 – DN100) Drawing:**

No	Part Name	Material
1	Body	A351 CF8M
2	Disc	SS316
3	Grand	SS316
4	Stem	SS316
5	Bolt	A193 B8M
6	Nut	A193 B8M
7	Gasket	SS316 + Graphite
8	Packing	Graphite
9	Pin	SS304
10	Gland Nut	SS316
11	Packing Gland	A351 CF8M

12	Eye Bolt	A193 B8M
13	Bonnet	A351 CF8M
14	Stem Nut	A439 D2
15	Screw	AISI 1025
16	Handwheel	A216 WCB
17	Gasket	SS316
18	Nut	A194 B8M

**Main Technical Parameter:**

<b>Normal Pressure</b>	10K
<b>Shell Test Pressure</b>	3.0 MPa
<b>Seal Test</b>	2.2 MPa
<b>Back Seal Test</b>	2.2 MPa
<b>Gas-Tightness Test</b>	0.6 MPa
<b>Max Working Pressure</b>	≤ 425°C

**Technical Specifications:**

1. Basic design and manufacture according to ASME B16.34 & BS 1873
2. Face to face dimension: ASME B16.10
3. Flange End: JIS 2238
4. Inspection and test: JIS F7400

## **Chuan Kok Hardware & Machinery Pte Ltd**

Address : 1783 Geylang Bahru, #01-02, Singapore 339708  
Telephone Number : +65 6294 2566  
Email Address : [info@chuankok.com](mailto:info@chuankok.com)  
Website : [www.chuankok.com](http://www.chuankok.com)  
Business Registration Number : 198201577Z  
Country of Registration : Singapore

### **Conditions of Use of Catalogue:**

The information in the catalogue are not binding and in order to improve distribution, Chuan Kok Hardware & Machinery Pte Ltd reserves the right to make any change including size and pressure ratings considered necessary at any time and without prior notice. According to the copyright and the civil law, any reproduction (also partial) of figures and texts of this catalogue by means of electronic, mechanical, photocopies, microfilms, recordings or other is forbidden without Chuan Kok Hardware & Machinery Pte Ltd's authorization.  
Catalogue Version: 2021

